

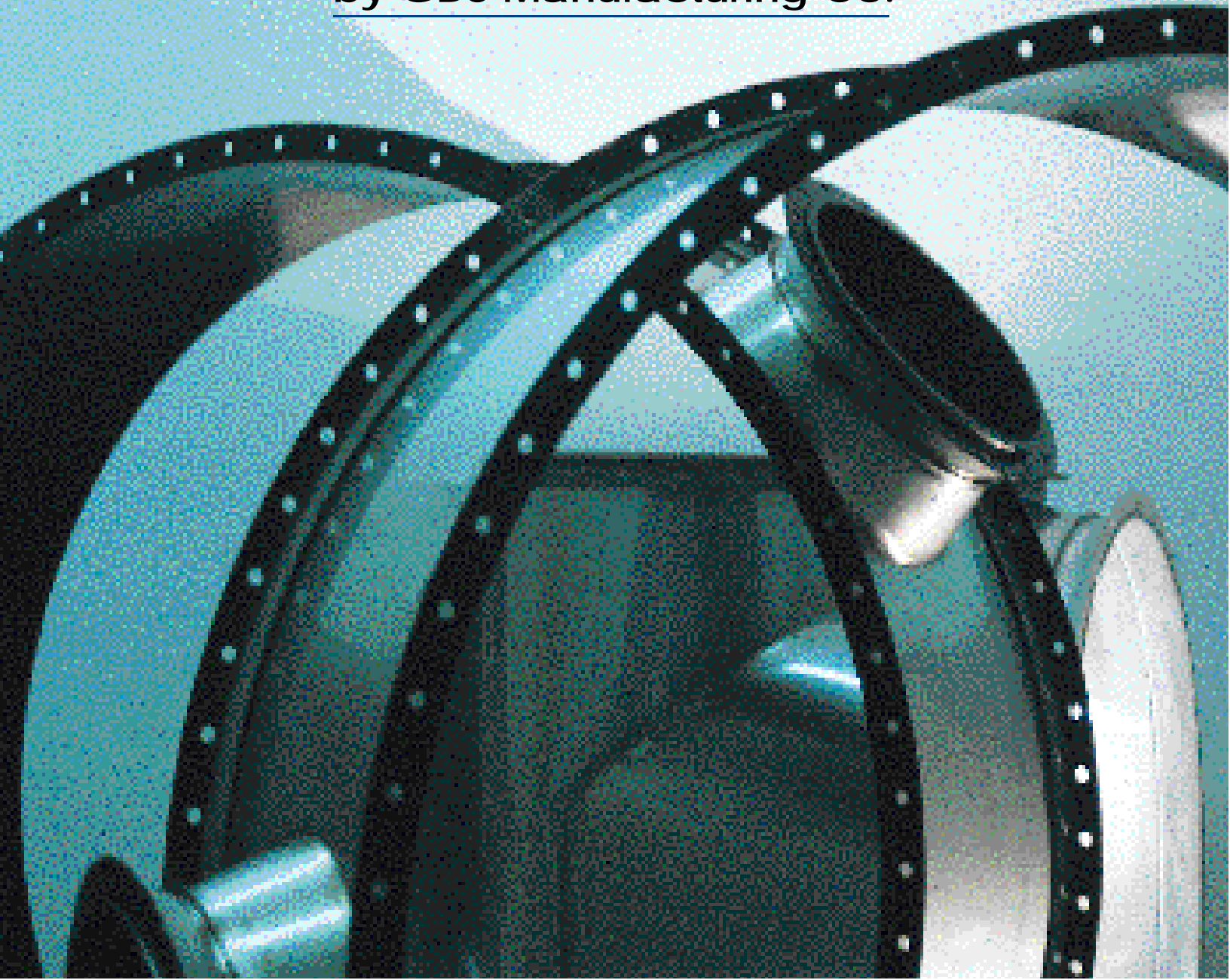

Kem-Tuff™

CHEMICAL AIR TRANSFER SYSTEMS
by GDS Manufacturing Co.





Kem-Tuff Acid Exhaust System

SEMICONDUCTOR FACILITY

This Kem-Tuff lateral is installed in a sub fab that serves as a clean air return. Tool hook-up can be performed without introducing contaminants from cutting or vapors, often encountered with polymeric exhaust systems.



What is **Kem-Tuff™**?

Kem-Tuff is an exhaust air transfer system designed to handle a wide range of corrosive exhaust streams, found in a variety of industrial applications. By combining the toughness of stainless steel with the corrosion resistance of HALAR-ECTFE fluoropolymer, Kem-Tuff offers the user a reliable and efficient means of venting corrosive fumes and vapors from clean rooms and other processing areas. Kem-Tuff is factory mutual rated for the removal of fumes and smoke without the use of sprinklers.

Kem-Tuff is manufactured by GDS MFG. in Williston, Vermont. GDS is the sole United States manufacturer exclusively devoted to the design and production of a coated steel exhaust system. Kem-Tuff products have been installed, and have lasted longer than any other product on the market to date. At GDS our goal is to bring innovative technology and continued reliability to our customers for Kem-Tuff Chemical Air Transfer Systems.

Why Use **Kem-Tuff™**?

- Kem-Tuff meets the Factory Mutual Requirements for fume and smoke removal without the use of sprinklers.
 - Kem-Tuff's fluoropolymer lining provides a wide range of chemical resistance.
 - Kem-Tuff's stainless steel substrate ensures a high level of mechanical reliability.
 - Kem-Tuff enables contamination-free installation
 - Kem-Tuff's modular design promotes cost effective handling and installation
 - Kem-Tuff is recyclable and reusable.
-

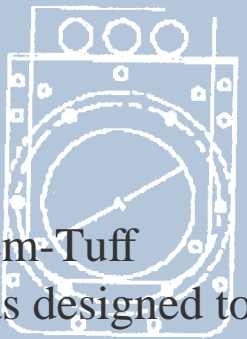

Kem-Tuff was designed to meet the increasing demands on industrial process exhaust systems.

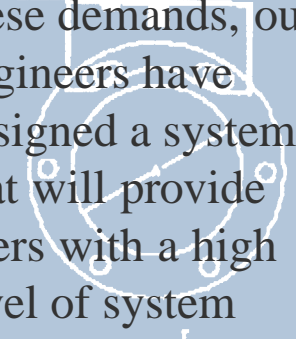

With a focus on these demands, our engineers have designed a system that will provide users with a high level of system integrity over a long life, resulting in low cost of ownership to the user.

The Kem-Tuff™ Advantage

Fume and Smoke Removal

Kem-Tuff has been approved by Factory Mutual for use in smoke and fume exhaust systems without the use of sprinklers. The HALAR fluoropolymer lining is a non-flammable, low smoke coating. When tested in accordance with ASTM E-84, Kem-Tuff had a flame spread rating of 5 and a smoke density rating of 15. The use of Kem-Tuff products eliminates the expense of buying, installing and maintaining sprinkler systems.

Corrosion Resistance

The HALAR-ECTFE fluoropolymer surface of Kem-Tuff provides an outstanding barrier against a wide range of chemicals. It is virtually unaffected by all corrosive chemicals commonly encountered in industry. HALAR-ECTFE is resistant to strong mineral and oxidizing acids, alkalis, metal etchants, and essentially all organic solvents except hot amines. HALAR's smooth surface characteristics make it resistant to the build-up of salts and other process by-products which can adversely affect the air handling capabilities of the system.

Mechanical Integrity

Kem-Tuff's stainless steel substrate is your best defense against fire and the external environment. The exterior 316L stainless steel surface ensures your exhaust system against damage from chemical spills, water, leaks, and impact damage. Kem-Tuff's fluoropolymer lining offers excellent mechanical properties including abrasion and cut-through resistance over a wide range of temperatures from cryogenic to 300°F. Kem-Tuff's bolted flange system provides the necessary reinforcement to allow system use over a wide range of both negative and positive operating pressure.

Contamination-Free Handling

A companion flange joining system makes the installation and handling of Kem-Tuff contamination-free and cost effective. With its modular component design, installing Kem-Tuff does not require any cutting, grinding, welding or use of bonding and sealing resins. It is ideal for clean work areas where particulates and fumes are undesirable.

Recyclable

Kem-Tuff does not readily absorb and retain the process chemicals it handles. Decontamination is simple, safe and effective. As a result, there is no need for costly hazardous waste disposal. Kem-Tuff components can easily be recycled for use at another location.

Kem-Tuff™ Quality Assurance

Quality Control

Kem-Tuff was designed to operate in harsh environments, over long periods of time, without interruption or failure. To ensure this performance, and to comply with Factory Mutual's rigorous audit procedures, each piece of Kem-Tuff is monitored for adherence to strict quality standards.

Before coating, the stainless steel substrate is checked to ensure complete welds and proper surface preparation. Proper surface preparation is required to ensure optimum coating performance. Once the coating is applied, each piece of Kem-Tuff is spark tested to ensure a void-free protective coating. Each piece is tracked through the process by a manufacturing control number.

In addition to our own internal measures of quality, GDS works closely with our suppliers to ensure consistency in the supply of our raw materials.

Testing

To ensure Kem-Tuff's performance in your system, GDS can provide you test coupons for actual in-service testing. Please contact our marketing department for more information.

Service and Support

GDS is ready to provide you a high level of support and service on every Kem-Tuff order. We can assist you in preparation of your detail drawings with our CAD system, to ensure optimum fitting design and joint placement. From conception to installation, GDS will work with you to ensure your Kem-Tuff System will provide you with the high level of performance your process demands.

Warranty

GDS provides a limited five year warranty on standard Kem-Tuff components to the original purchaser. Please request a copy of the Kem-Tuff Chemical Air Transfer Systems Limited Warranty for a complete disclosure of the terms and conditions of this warranty.

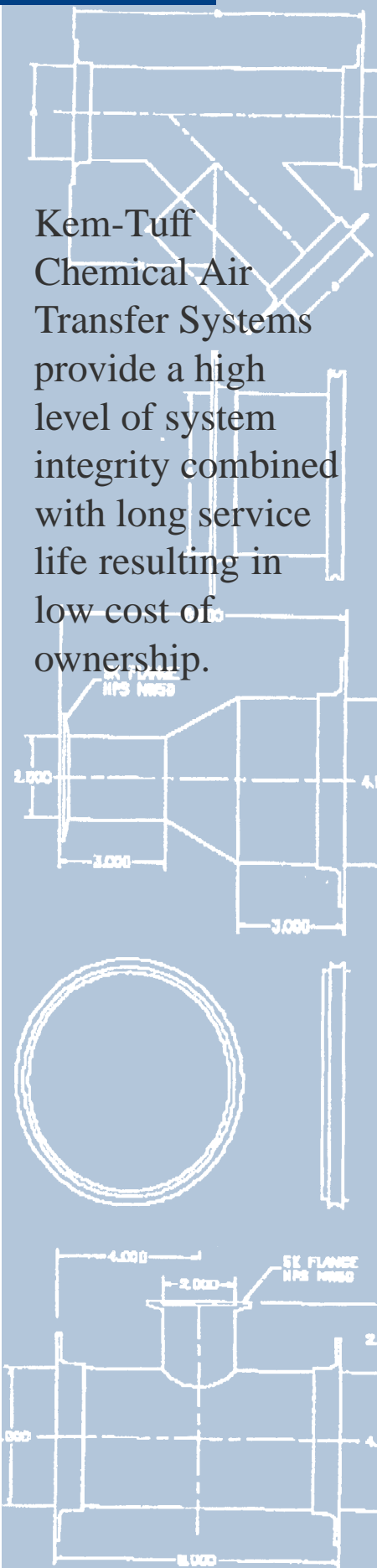

Kem-Tuff
Chemical Air
Transfer Systems
provide a high
level of system
integrity combined
with long service
life resulting in
low cost of
ownership.

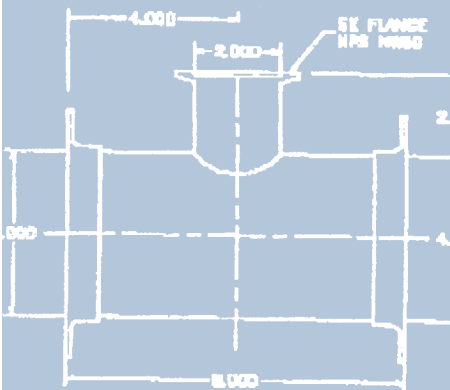

Kem-Tuff™ Design & Selection Criteria

| | |
|------------------------|---|
| Base Metal: | The base metal for all straight duct and fittings is 316L stainless steel. |
| Interior Coating: | HALAR-ECTFE Fluoropolymer electrostatically applied powder coating. |
| Angle Flange: | Van Stone Type304 Stainless Steel built in accord with SMACNA Industrial Duct Construction Standards. |
| Gasket Material: | Pre-cut PTFE envelope design, with neoprene filler. Also available: Gore-TEX® joint sealant. |
| System Classification: | Standard construction is SMACNA Class 1 Industrial Duct, for up to -6 inch WG. Kem-Tuff can be built to other design ratings upon request. |
| Fitting Design: | Standard fitting dimensions are per SMACNA Industrial Duct Construction Standards. Special fittings can be built to customer specification. |
| Adapters: | Specially designed taps and flange adapters are available to enable Kem-Tuff to be joined to existing systems. |
| Test Coupons: | 4" x 4" Test Coupons are available for actual in-service testing. |

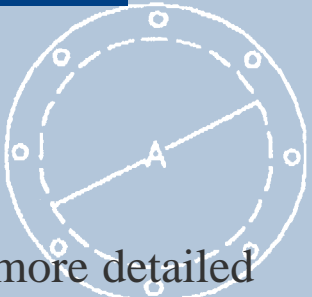

For more detailed information on Kem-Tuff products please request any or all of these brochures:



Kem-Tuff
Industrial Exhaust
Ductwork
Specification



Kem-Tuff
Expanded Chemical
Resistance Guide



Kem-Tuff
Standards Guide

Kem-Tuff
Ordering and
Detailing Kit



Kem-Tuff
OTS

Kem-Tuff™ OTS™

In the event of a process upset, or worse, a tool fire, OTS will maintain its mechanical integrity and ensure that harmful and unwanted contaminants are continually exhausted from the cleanroom.

To facilitate fast, efficient and contamination-free tool hook-ups, GDS provides Kem Tuff OTS. GDS has available a large selection of straight pipe duct and fittings in sizes ranging from 4-inch through 10-inch ready for immediate shipment to your location. OTS eliminates costly delays due to long lead times and manufacturing schedules. GDSengineers have designed a fully integrated process exhaust system that allows you to make tool connections without cutting, grinding, or the use of hazardous resins and adhesives. Balancing and control are attained with either a blast-gate, or through the use of GDS's new low-leak PTFE damper assembly. For more information see the OTS Standards Guide.

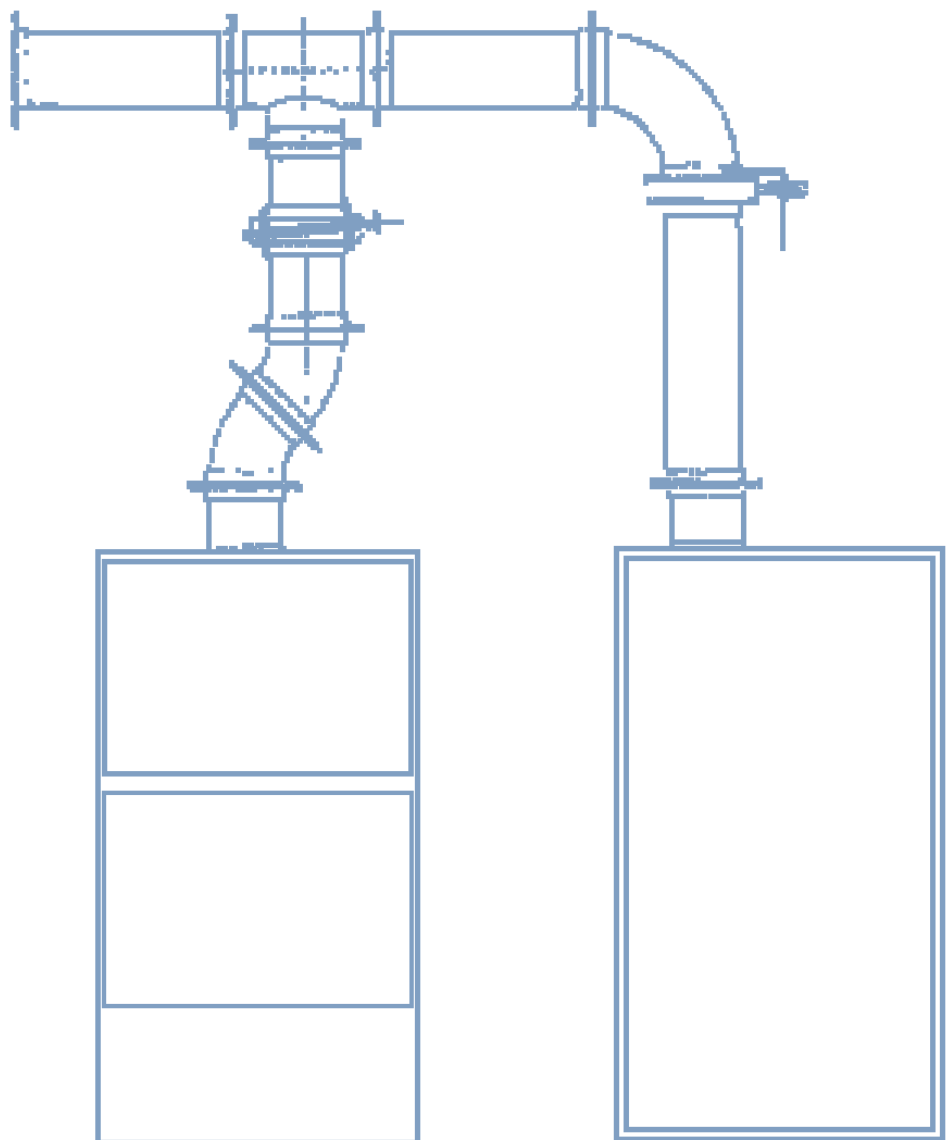

Kem-Tuff™

Standard Components

GDS

can assist you in the design of special fittings to meet your system requirements.

Our CAD services are available to assist you in detailing your final layout, to ensure optimal fitting and joint design and placement.

For a complete list of standards and order sheets, please request the Kem-Tuff Standards and Ordering Guide.

All Kem-Tuff components are fabricated in accord with the most recent SMACNA Industrial Duct Construction Standards for Class 1 industrial duct. Kem-Tuff components are typically built to standard dimensions to promote ease of installation, and allow for future interchangeability. Straight pipe is generally fabricated in 47 inch nominal lengths. At 47 inches, the angle flanges used to join Kem-Tuff will also meet most SMACNA reinforcing requirements over a wide range of pressure classifications. All fittings are manufactured with Van Stone fittings. This list identifies our most common standard fittings.

- STRAIGHT PIPE
- 90° ELBOW 5 GORE
- 60° ELBOW 3 GORE
- 45° ELBOW 3 GORE
- 30° ELBOW 2 GORE
- 22° ELBOW 2 GORE
- WYE CONFIGURATIONS
- SQUARE TO ROUND TRANSITIONS
- 45° TAKEOFF
- CONCENTRIC TAKEOFF
- CONCENTRIC REDUCER
- ECCENTRIC REDUCER
- OFFSET
- OFFSET REDUCER
- HORIZONTAL BLASTGATE
- VERTICAL BLASTGATE
- BALANCE DAMPER
- END CAPS
- LATERAL TAKEOFF
- 90°, 180°, CROSS
- CUSTOM DESIGN

Kem-Tuff™ Duct & Flange Dimension Guide

The chart below lists the duct gauge sizes, angle flange dimensions and bolt patterns for Class 1 industrial duct, designed to operate at pressure class -6 WG. This is a typical operating pressure found in semiconductor processing.

| DUCT | | ANGLE FLANGE DIMENSIONS | | | | | BOLT | |
|------|-------|-------------------------|------------------|-----------------|--------------|----------------|-----------|--------|
| Size | Gauge | Inside Diameter | Outside Diameter | Angle Thickness | Angle Height | B.C. Dimension | Hole Size | Number |
| 4 | 20 | 4-1/8 | 5-1/8 | 10ga. | 1 | 5-3/8 | 9/32 | 6 |
| 6 | 20 | 6-1/8 | 9-1/8 | 3/16 | 1-1/2 | 7-3/4 | 9/16 | 6 |
| 8 | 20 | 8-1/8 | 11-1/8 | 3/16 | 1-1/2 | 9-3/4 | 9/16 | 8 |
| 10 | 20 | 11-1/8 | 13-1/8 | 3/16 | 1-1/2 | 11-3/4 | 9/16 | 8 |
| 12 | 20 | 13-1/8 | 15-1/8 | 3/16 | 1-1/2 | 13-3/4 | 9/16 | 12 |
| 14 | 20 | 15-1/8 | 17-1/8 | 3/16 | 1-1/2 | 15-3/4 | 9/16 | 12 |
| 16 | 20 | 17-1/8 | 20-1/8 | 3/16 | 2 | 18-3/8 | 9/16 | 16 |
| 18 | 20 | 19-1/8 | 22-1/8 | 3/16 | 2 | 20-3/8 | 9/16 | 16 |
| 20 | 20 | 22-1/8 | 24-1/8 | 3/16 | 2 | 22-3/8 | 9/16 | 20 |
| 22 | 20 | 24-1/8 | 26-1/8 | 3/16 | 2 | 24-3/8 | 9/16 | 20 |
| 24 | 20 | 26-1/8 | 28-1/8 | 3/16 | 2 | 26-3/8 | 9/16 | 20 |
| 26 | 20 | 28-1/4 | 30-1/8 | 3/16 | 2 | 28-3/8 | 9/16 | 24 |
| 28 | 20 | 30-1/4 | 32-1/4 | 3/16 | 2 | 30-1/2 | 9/16 | 24 |
| 30 | 20 | 32-1/4 | 34-1/4 | 3/16 | 2 | 32-1/2 | 9/16 | 28 |
| 32 | 20 | 34-1/4 | 36-1/4 | 3/16 | 2 | 34-1/2 | 9/16 | 28 |
| 34 | 20 | 36-1/4 | 38-1/4 | 3/16 | 2 | 36-1/2 | 9/16 | 32 |
| 36 | 20 | 36-1/4 | 40-1/4 | 3/16 | 2 | 38-1/2 | 9/16 | 32 |
| 38 | 18 | 38-1/4 | 42-1/4 | 3/16 | 2 | 40-1/2 | 9/16 | 36 |
| 40 | 18 | 40-1/4 | 44-1/4 | 3/16 | 2 | 42-1/2 | 9/16 | 36 |
| 42 | 18 | 42-1/4 | 46-1/4 | 3/16 | 2 | 44-1/2 | 9/16 | 40 |
| 44 | 18 | 44-1/4 | 48-1/4 | 3/16 | 2 | 46-1/2 | 9/16 | 40 |
| 46 | 18 | 46-1/4 | 50-1/4 | 3/16 | 2 | 48-1/2 | 9/16 | 44 |
| 48 | 18 | 48-1/4 | 52-1/4 | 3/16 | 2 | 50-1/2 | 9/16 | 44 |
| 50 | 16 | 50-1/4 | 54-1/4 | 3/16 | 2 | 52-1/2 | 9/16 | 48 |
| 52 | 16 | 52-1/4 | 56-1/4 | 3/16 | 2 | 54-3/8 | 9/16 | 50 |
| 54 | 16 | 54-1/4 | 58-1/4 | 3/16 | 2 | 56-3/8 | 9/16 | 50 |
| 56 | 16 | 56-1/4 | 60-1/4 | 3/16 | 2 | 58-3/8 | 9/16 | 54 |
| 58 | 16 | 58-1/4 | 62-1/4 | 3/16 | 2 | 60-3/8 | 9/16 | 56 |
| 60 | 16 | 60-1/4 | 64-1/4 | 3/16 | 2 | 62-3/8 | 9/16 | 58 |
| 70 | 14 | 70-1/4 | 74-1/4 | 3/16 | 2 | 72-3/8 | 9/16 | 68 |

All dimensions are in inches.

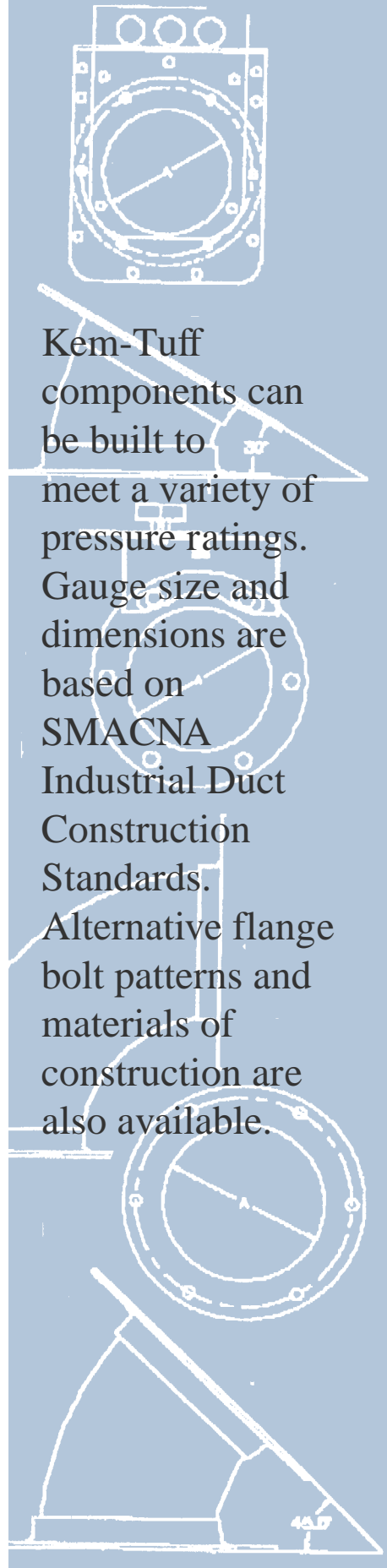

Kem-Tuff™ Chemical Resistance Guide

Below is a partial list of chemicals capable of corrosive or chemical attack on conventional metallic and polymeric materials of construction. A complete list of chemical compatibility can be found in the Kem-Tuff/HALAR Expanded Chemical Resistance Guide.

| CHEMICAL | Maximum Use Temp | | CHEMICAL | Maximum Use Temp | |
|-----------------------|------------------|--------|---------------------------|------------------|--------|
| | Deg.F | Deg. C | | Deg.F | Deg. C |
| Acetic Acid 90% | 300 | 149 | Hypochlorous Acid | 300 | 149 |
| Acetic Acid Glacial | 212 | 100 | Magnesium Hydroxide | 300 | 149 |
| Acetone | 121 | 50 | MEK | 121 | 50 |
| Alcohol, Butyl | 300 | 149 | MIBK | 121 | 50 |
| Alcohol, Ethyl | 300 | 149 | Nitric Acid 50% | 212 | 100 |
| Alcohol, Isopropyl | 300 | 149 | Nitric Acid 70% | 121 | 50 |
| Aluminum Chloride | 300 | 149 | N-MP | 73 | 23 |
| Aluminum Hydroxide | 300 | 149 | Ozone | 212 | 100 |
| Ammonia, Gas | 212 | 100 | Phosphoric Acid 30% | 300 | 149 |
| Ammonium Chloride | 300 | 149 | Phosphoric Acid 85% | 300 | 149 |
| Ammonium Fluoride | 300 | 149 | Plating Solutions, Brass | 212 | 100 |
| Ammonium Hydroxide | 300 | 149 | Plating Solutions, Chrome | 212 | 100 |
| Ammonium Phosphate | 300 | 149 | Plating Solutions, Copper | 212 | 100 |
| Ammonium Sulfate | 300 | 149 | Plating Solutions, Gold | 212 | 100 |
| Chlorine Dioxide | 212 | 100 | Plating Solutions, Nickel | 212 | 100 |
| Chlorine Gas, Dry | 212 | 100 | Plating Solutions, Silver | 212 | 100 |
| Chlorine Gas, Wet | 212 | 100 | Plating Solutions, Tin | 212 | 100 |
| Chlorobenzene | 121 | 50 | Plating Solutions, Zinc | 212 | 100 |
| Chlorosulfonic Acid | 121 | 50 | Potassium Hydroxide 50% | 300 | 149 |
| Chromic Acid 50% | 212 | 100 | Sodium Bisulfite | 300 | 149 |
| Coke Oven Gas | 212 | 100 | Sodium Chloride | 300 | 149 |
| Dilisobutyl Ketone | 121 | 50 | Sodium Fluoride | 300 | 149 |
| Dimethyl Formamide | 212 | 100 | Sodium Hydroxide 50% | 250 | 120 |
| Dimethyl Sulfoxide | 212 | 100 | Sulfur Dioxide | 212 | 100 |
| Ferric Chloride | 300 | 149 | Sulfuric Acid 50% | 250 | 120 |
| Freon F-22 | 212 | 100 | Sulfuric Acid 93% | 250 | 120 |
| Freon F-113 | 212 | 100 | Sulfuric Acid 98% | 250 | 120 |
| Hydrobromic Acid 50% | 300 | 149 | Trichloroacetic Acid | 121 | 50 |
| Hydrochloric Acid 37% | 300 | 149 | Urea | 212 | 100 |
| Hydrofluoric Acid 10% | 300 | 149 | Water Deionized | 300 | 149 |
| Hydrofluoric Acid 49% | 250 | 120 | Zinc Chloride | 300 | 149 |
| Hydrogen Peroxide 50% | 250 | 120 | Zinc Sulfate | 300 | 149 |
| Hydrogen Peroxide 90% | 121 | 50 | | | |

The information contained in this table is based on laboratory testing, field experience and technical estimation, and should only be used as a guide. Actual environmental testing should be conducted before determining final suitability.

In the construction of Kem-Tuff Components, HALAR-ECTFE serves as the protective layer against corrosive attack. HALAR-ECTFE fluoropolymer provides outstanding chemical resistance and barrier properties. It is virtually unaffected by all corrosive chemicals commonly encountered in industry.

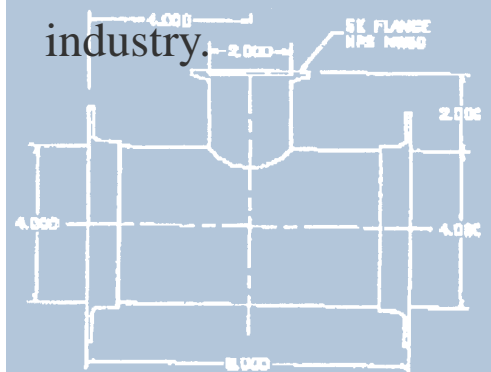

DESIGNED FOR USE IN:

- Bleaching Facilities
- Chemical Processing
- Clean Rooms
- Etching Lines
- Food Processing Plants
- Hospitals
- Laboratories
- Municipal Water & Sewage Facilities
- Metal Processing & Refining Operations
- Pharmaceutical Plants
- Plating & Pickling Operations
- Printed Circuit Board Manufacturing
- Pulp & Paper Processing
- Semiconductor Processing
- Any Application where Corrosive Exhaust is Generated

Kem-Tuff™ Chemical Air Transfer Systems

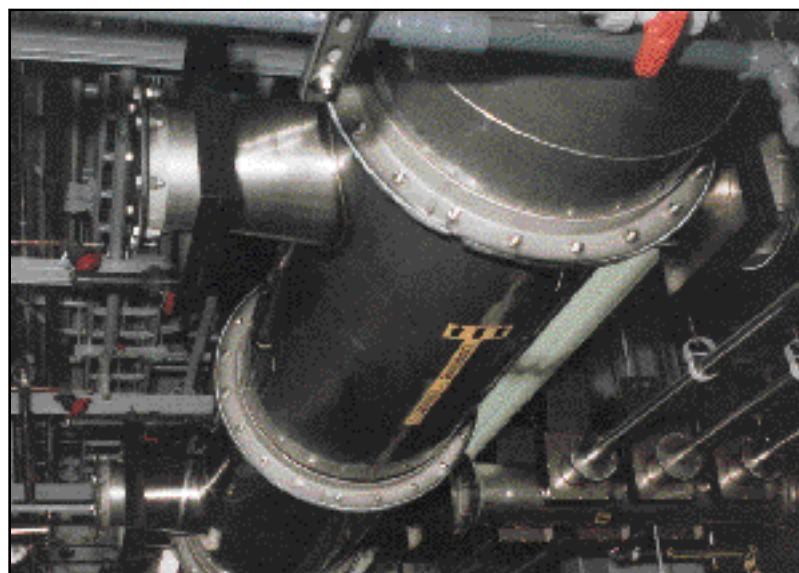
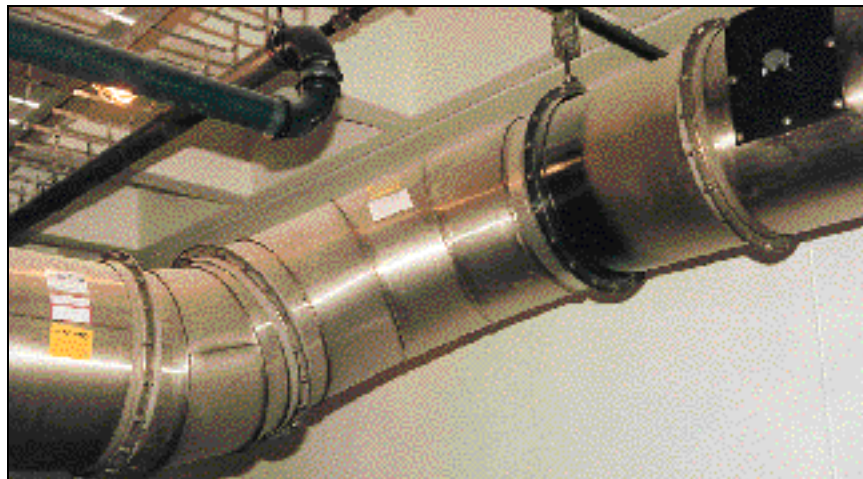

KemTuff™

Chemical Air Transfer Systems

Manufactured by:

GDS Manufacturing
2 Chad Lane
Williston, VT 05495
Phone: 802-862-7610
Fax: 802-862-7601

GDS Manufacturing
571 Moon Clinton Road
Moon Township, PA 15108
Phone: 800-899-7610
Fax: 412 264-6735

All statements, information, and data given herein are believed to be accurate and reliable but are presented without guaranty, warranty or responsibility of any kind, express or implied. Statements or suggestions concerning possible use of our products are made without representation or warranty that any such use will provide the same results. The user should not assume that all safety measures are indicated, or that other measures may not be required.
